

# Limited Use/Limited Application Elevator Design Guide

ASME A17.1, Part V, Section 5.2

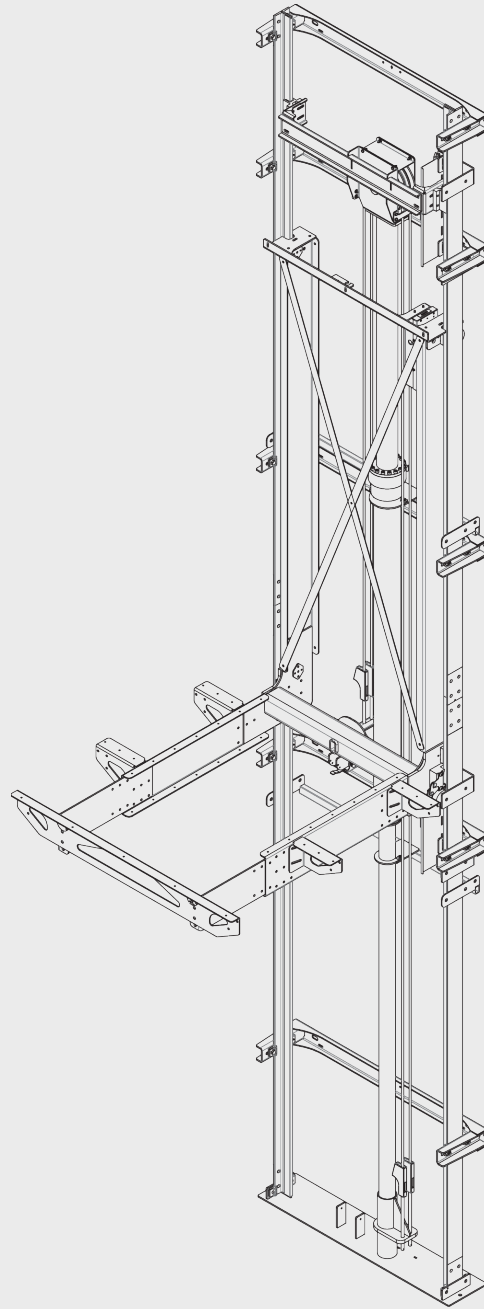

LULA Hydraulic Drive

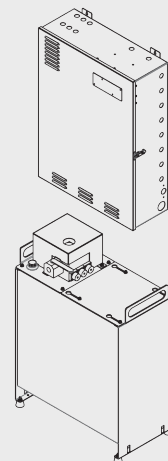

# Table of Contents

- About Symmetry Elevating Solutions ..... 2
- Elevation-Limited Use/Limited Application Elevator ..... 3
- Component Identification ..... 4
- Common Specifications ..... 5
- Hoistway Configuration ..... 6
- Entrance Frame ..... 7
- Hydraulic Drive-Machine Rooms..... 8
- Hydraulic Drive-MRL Machine Space .....9-10
- Hoistway-Construction Outline ..... 11
- Hoistway- Typical Rail Backing Construction..... 12
- Configurations-Single Opening ..... 13
- Configurations-Opposite Opening ..... 14
- Configurations-90 Degree Opening..... 15

## About Symmetry Elevating Solutions

Symmetry is a beautifully crafted, expertly engineered accessibility-related product line proudly **made in the U.S.A.** at the Bella Elevator LLC manufacturing plant. Promoted and sold by our  exclusive nationwide network of carefully selected Symmetry partners and associates, Symmetry offers residential elevators, vertical platform lifts (VPL), limited use/limited application (LULA) elevators and vertical reciprocating conveyors (VRC).

Strictly following national code guidelines and adhering to local jurisdiction requirements and variances, Symmetry products are ADA and ASME compliant and manufactured to meet the end users' specific needs. Symmetry Elevating Solutions representatives possess a wealth of knowledge and experience and are committed to excellence for the life of the product-before, during and after project completion.

With dealer locations spanning North America, we are equipped to meet the accessibility needs of a wide spectrum of clients, from home and business owners, to schools, municipalities and other governmental entities.

**Please note that this guide is for planning purposes only, applies exclusively to national code and should not be used for construction.** Prior to construction, please contact your local Symmetry Elevating Solutions representative and request a job-specific set of elevator plans to ensure that you obtain the accurate dimensions and requirements for your project.

Your representative will also assist you to identify resources to ensure that your project plans will comply with the applicable state and local codes and the permitting authorities.

# Elevation

## Limited Use/Limited Application elevator

### What is a Limited Use/Limited Application Elevator?

The symmetry LULA elevator is designed to comply with ASME A17.1 Section 5.2 and the Americans with Disabilities Act (ADA). LULA elevators are intended to provide access for low occupancy/low rise commercial buildings where a traditional passenger elevator is not feasible or required by code. Due to the design intent, LULA elevators are limited by speed, travel distance, and capacity.

When only the highest level of safety is your standard, the Elevation LULA elevator is the optimal product for your project. Leading the industry in quality, style and design, Elevation by Symmetry is engineered and designed for limited commercial, as well as residential, use.

The Elevation is ideal for applications up to six stops and up to 50 feet of travel (with travel variance) and is designed for use in schools (and other educational settings), churches, multi-family housing units, libraries and more.



#### Symmetry LULA elevators are available with:

- Shallowest pit depth required in the industry
  - 13 inch pit with elastomeric bumpers (ASME A17.1 year 2013 & prior)
  - 14 inch pit with buffer springs (ASME A17.1 year 2016)
- Shortest overhead required in the industry for existing buildings
  - 104 inches with alternate means
- All light sources are powered by energy-efficient LED technology
  - Including car operating panel (COP), car lights and directional indicators

# Component Identification

Roped hydraulic drive

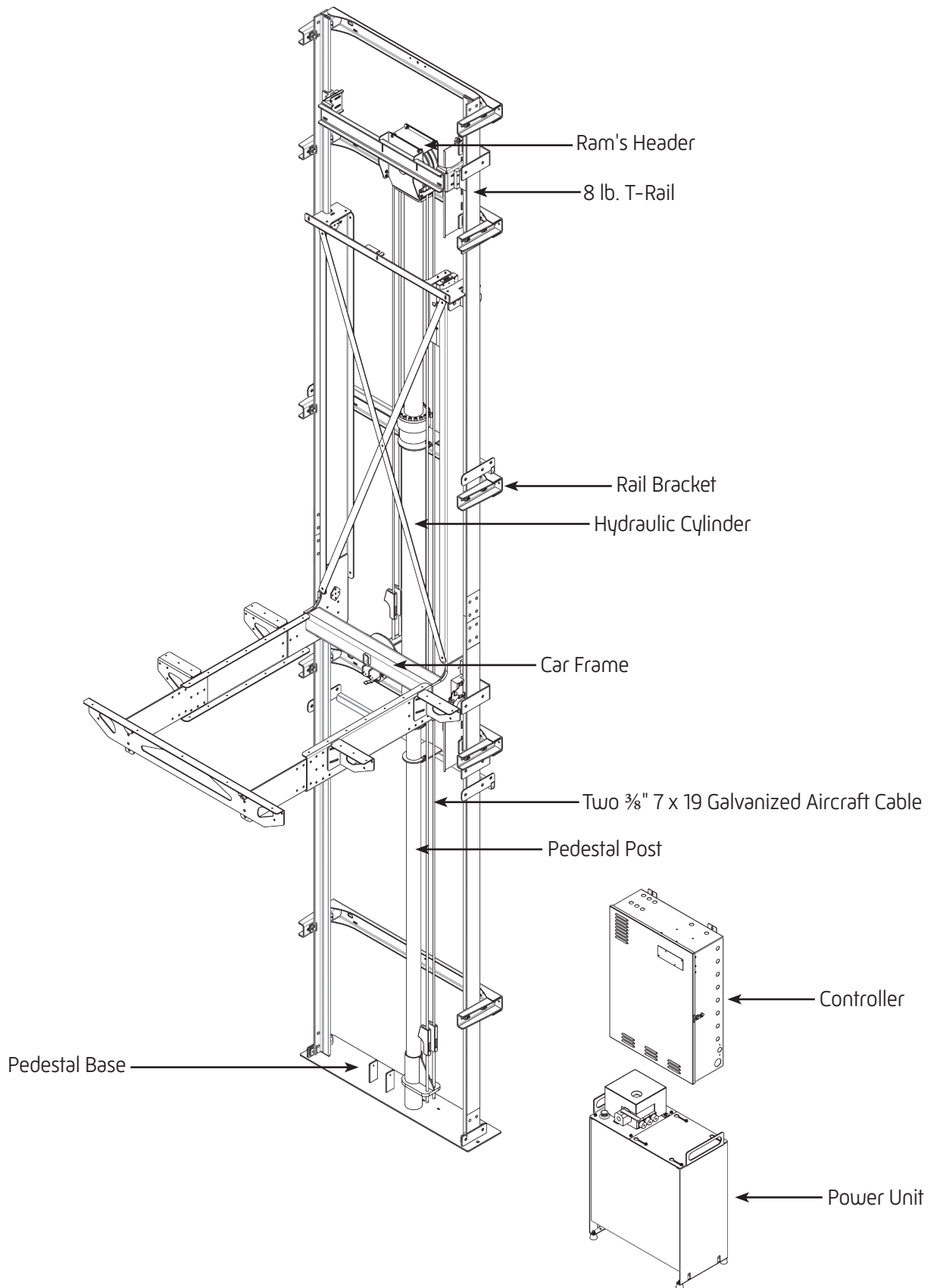

# Common Specifications

## For LULA elevator equipment

### Standard Features

- Rated Capacity: 1,400 lbs. (635 kg)
- Opening: Single
- Lifting Height: Up to 25'0"
- Power supply: 208/230 VAC, 1 PH, 30 amp, 60 Hz, 4 HP
- Speed: 30 fpm (.15 M/S)
- Automatic self-leveling
- Drive System: 2:1 roped hydraulic
- Stops: Two
- Doors: 3'0" x 6'8" automatic horizontally sliding, two speed hoistway and car door; full-height light curtain
- Pit Depth: 13", 14" if buffer springs required
- Overhead: New construction 132"; existing construction as low as 104" with alternative means
- Selective Collective Programmable Logic Controller (PLC)
- Car-mounted directional indicator with audible signals
- 4 HP submersible pump and motor for quiet operation
- Two-speed control valve
- Low oil protection
- Single-stage hydraulic jack and two 3/8 inch aircraft cables using wedge sockets
- 8 lb. T-rail
- Heavy-duty rollers and guides
- Homing timer
- Passing Chime
- Digital position indicator
- Warranty: Three-year limited parts

### Safety Features

- ADA hands-free phone
- Keyed in-car stop switch and alarm button
- Emergency lighting in car interior
- Uninterruptible Power Supply (UPS) for car lowering and power opening of the car and hoistway doors in the event of a power failure
- Emergency manual lowering
- Broken/slack suspension safeties
- Overspeed valve
- ETL, UL or CSA certified components
- Tactile/braille characters for COP and landings
- Elastomeric bumpers (ASME A17.1 year 2013 and prior) or buffer springs (ASME A17.1 year 2016 and later)

### Platform Sizes

(Custom sizes and designs available)

- 48"W x 54"D
- 42"W x 54"D
- 42"W x 60"D
- 51"W x 51"D (90° applications only)

### Enter/Exit Configurations

- Same Side standard
- 90° Adjacent
- Straight-Through

### Car Features

- 7'0" interior car height
- Ivory powder-coat painted steel or Unfinished Red Oak flat panel car walls with matching ceiling\*
- Brushed Stainless Steel car entrance on steel car (strike column, return column and transom)
- Matching entrance on wood car
- Ivory powder-coat painted steel 3'0" x 6'8" Two Speed Doors
- Brushed Stainless Steel handrail
- Unfinished plywood floor with sill set for 1/4 inch (flooring by others)
- Four recessed LED lights with Black trim rings

### Optional Features

- Machine room less (MRL)
- Stops: Up to six (with variance)
- Custom wood cars
- Stainless Steel cars
- Steel or wood car prepped for glass (glass by others)
- Laminate applied car panels
- Overspeed governor
- Speed: 40 fpm with variance
- Lifting height: Up to 50'0" with variance and derated capacity
- Three-Phase motor and controller (208/230 VAC; 3 PH, 20 amp, 60 Hz, 5 HP)
- Buffer springs (minimum 14 inch pit required)
- Landing position indicator
- Keyed Hoistway access
- Phase 1 and Phase 2 fire service
- Phone line monitoring system
- LED lights with Brushed Nickel, Bronze or White trim rings
- Ventilation system
- Audio visual two way communication system (required by ASME A17.1-2019 and later)
- 3D light curtain (required by ASME A17.1-2019 and later)
- Keyed controls
- Extended warranty

\* Wood cars require fire coat to be added in commercial settings

*Symmetry LULA elevators are designed to comply with ASME A17.1 Section 5.2 and the Americans with Disabilities Act (ADA).*

*All LULA elevators are limited by speed, travel and capacity in order to comply with applicable code.*

# Hoistway Configuration

Limited Use/Limited Application elevator

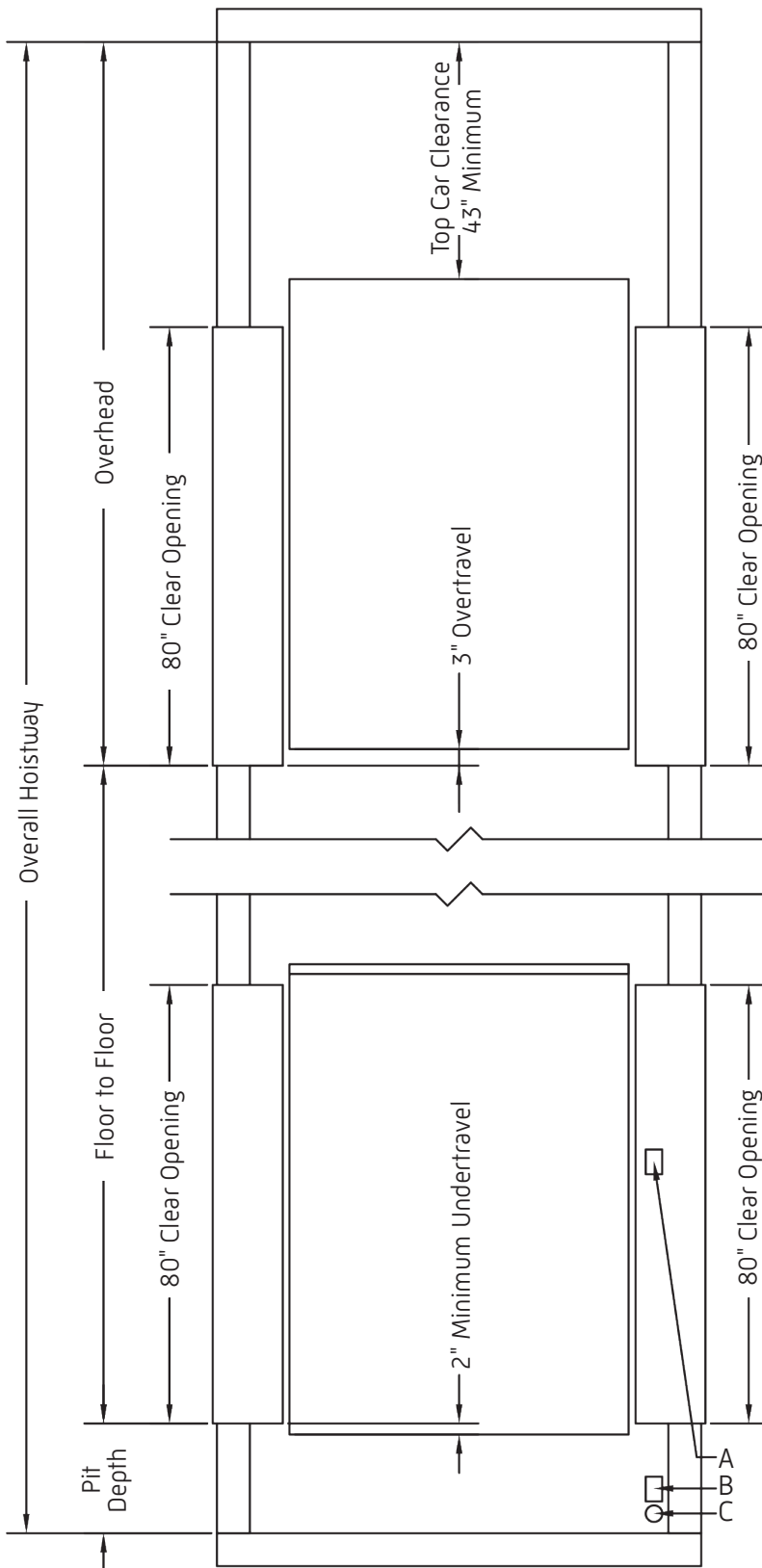

## Notes:

- 1) Hoistway must be free of any obstructions unrelated to the elevator operation (i.e. pipes, ducts, etc.).
- 2) The minimum floor-to-floor travel between any two entrances on the same wall is 98½ inches (8'2½").
- 3) The minimum floor-to-floor travel between straight-through or 90° sides is 26 inches.
- 4) The minimum floor-to-floor travel between any two landings is 16 inches.
- 5) The minimum pit depth is 13 inches (14 inches if buffer springs are required).
- 6) The minimum overhead is 8'8" for existing construction or 11'0" for new construction.

## Work by General Contractor:

- A) Pit Light Switch installed 4'0" above the lower finished floor
- B) Pit GFCI Duplex Receptacle
- C) Pit Light

# Entrance Frame

Left-hand shown, right-hand opposite

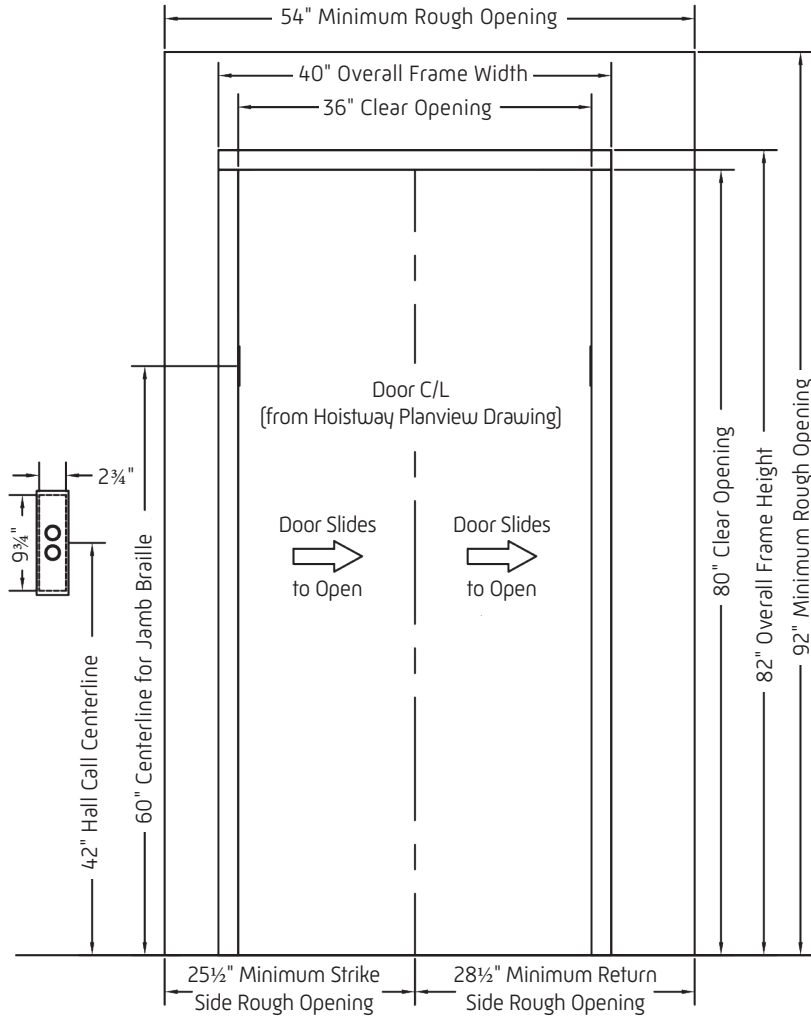

## Notes:

- 1) Hoistway entrances are manufactured in accordance with 1½ hour fire-rated construction.
- 2) Hoistway walls to have a fire endurance rating not less than required by Section 110 (1996) or Section 2.1 (2000+) ASME A17.1 Elevator Safety Code.
- 3) Furnishing, installing and maintaining the required fire rating of elevator hoistway walls, including the penetration of the fire wall by elevator fixture boxes, is not the responsibility of the elevator contractor or manufacturer.
- 4) The interface of the hoistway wall with the hoistway entrance shall be in strict compliance with the entrance manufacturer's requirements in order to retain fire rating and label validity of the elevator hoistway doors and frame.
- 5) Hoistway walls at entrances should be left open for the full width of the shaft until after door sills and frames are set in place. If this is not feasible, leave a 54"W x 92"H rough opening.
- 6) Filling and grouting by General Contractor.

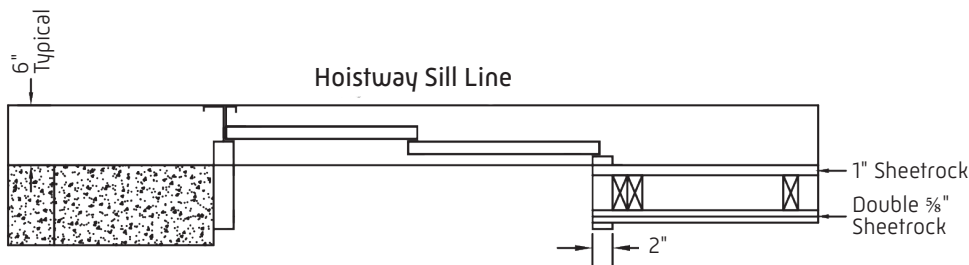

**Masonry Construction Sill Anchors**  
 (6) ¾" x 3"  
 Wedge Concrete Anchors

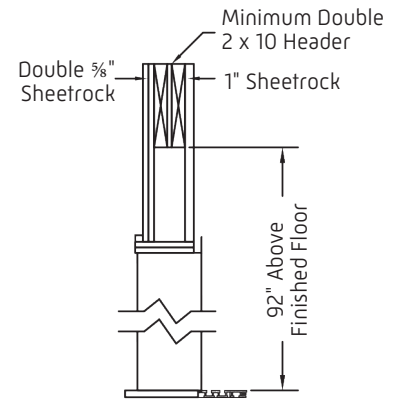

**Wood/Drywall Construction Sill Anchors**  
 (6) ¾" x 4"  
 Lag Bolts, Zinc

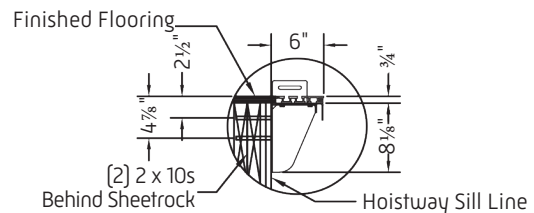
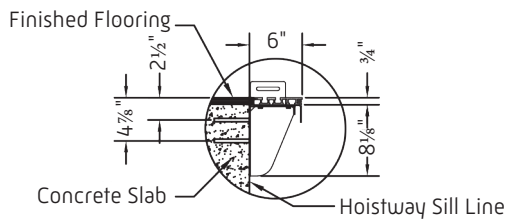

# Hydraulic Drive Machine room

## Standard Machine Room

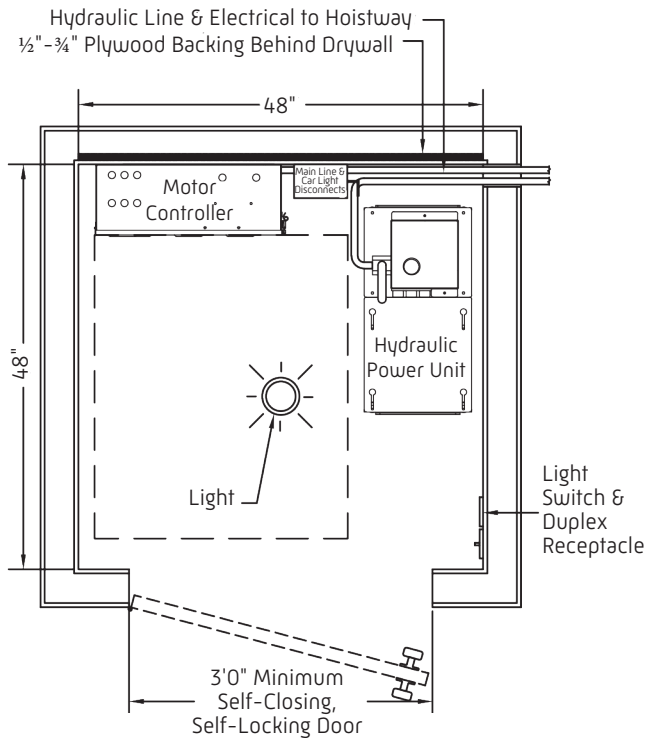

## Compact Machine Room

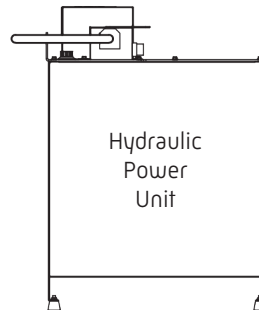
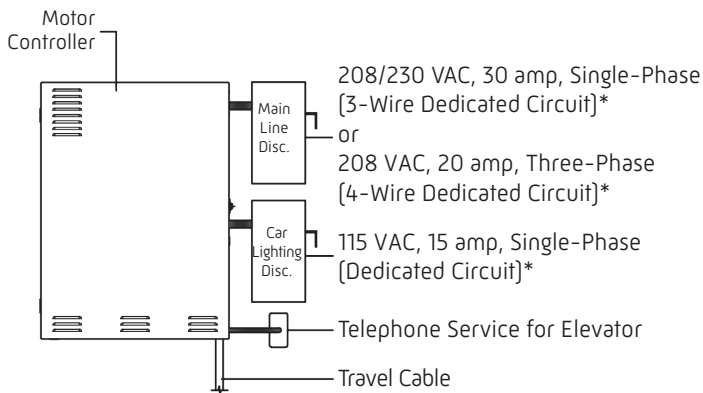
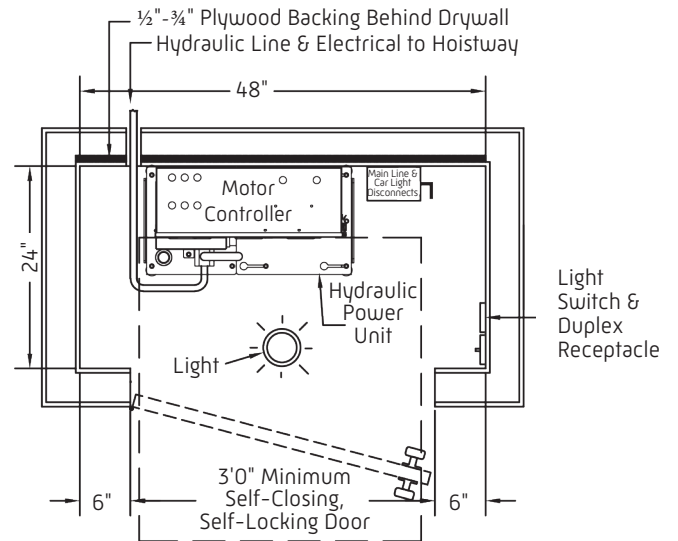

**Motor Controller**  
22"W x 30"H x 8"D

**Main Line Disconnect**  
Single-Phase  
Square D-H322N or Equivalent  
2 Pole with Auxiliary Contact or 3 Pole  
Three-Phase  
Square D-H321N or Equivalent  
3 Pole with Auxiliary Contact

**Car Lighting Disconnect**  
Square D-G221N or Equivalent

**Hydraulic Power Unit**  
24 1/4"W x 33 1/2"H x 12 3/4"D

### Notes:

1. The elevator machine room location and layout must meet the code requirements defined by the local authority having jurisdiction.
2. 30" wide x 36" deep clear working space in front of the motor controller and disconnects as required by National Electrical Code (NFPA 70).
3. The disconnects and light switch must be located on the strike side of the machine room door.
4. The hydraulic power unit must be located within 40'0" of the cylinder.
5. The machine room must be free of all equipment not related to the elevator.
6. The minimum machine room headroom is 7'0".
7. The machine room must be maintained between 50°F and 80°F, with relative humidity from 5% to 95%, non-condensing.

\*Feeding breaker must not be a GFCI



# Hydraulic Drive MRL machine space

LULA Elevator machine space for Machine Room-Less (MRL) application

Machine space door removed for clarity  
Hoistway wall removed for clarity

The machine space wall thickness must be 8" when disconnects are required to be in the machine space

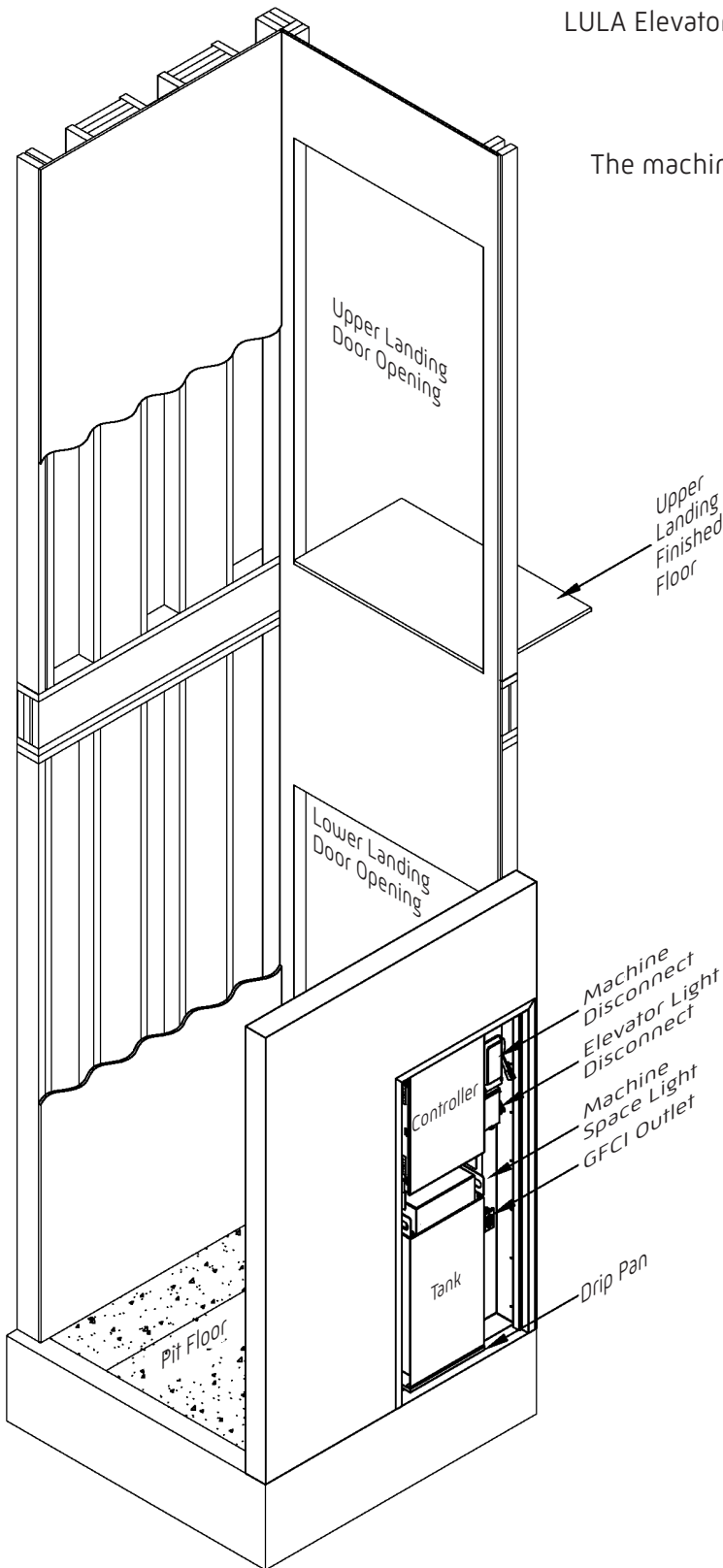

1. Lighting: The machine space must have at a minimum 19 ftc at the floor level.
2. The outlet, lighting and disconnects must be located on the strike side of the door.
3. Self closing/self locking door required.
4. A 36" door is required when a fused disconnect is required inside the machine space.
5. The 36" door should be used when an 8" wall thickness is used.
6. A splash guard is required when the hoistway is sprinkled.
7. Do not block the door. Keep clear at all times.
8. Heat load: At two cycles per hour, the average heat load will be equivalent to an 80-Watt light bulb operating continuously; at five cycles per hour, the average heat load will be equivalent to a 200-Watt light bulb operating continuously.
9. The minimum machine space headroom is 7'0".
10. The machine space must be maintained between 50°F and 80°F, with relative humidity from 5% to 95%, non-condensing.

# Hydraulic Drive MRL machine space



1. 3'0" wide x 6'8" tall x 8" deep door shown with disconnects in the machine space.  
- 2'8" x 6'8" x 5 3/4" deep door available with disconnects mounted remotely.
2. Doors are available from elevator manufacturer or may be provided by others.
3. If providing machine & lighting disconnects in the machine space, an 8" wall depth is required.
4. 30" x 36" working space required by NEC in front of door.
5. Filler panels will be provided to prevent entry into the hoistway.  
- There are moving parts behind the filler panels. The filler panels do not need to be removed to service the elevator.
6. No material other than that related to the elevator's operation is permitted in the machine space.
7. Machine space access door must be accessible from inside the building and can be located at any landing.

# Hoistway

## Construction outline

### Rail Backing & General Hoistway

- Provide adequate rail backing per drawings. For vertical spans between floor systems that exceed 10'0", please consult a structural engineer. The wall must be capable of supporting the loads without deflecting more than 1/8 inch.
- The hoistway must be constructed square and plumb within 1/8 inch tolerance throughout.
- The hoistway must be free of any obstructions not related to the operation of the elevator (i.e. sprinklers, pipes, ducts, etc.).
- The structure of the hoistway must allow for installation of a chain hoist to transfer materials during installation.
- The maximum rail bracket spacing is 6'0".

### Pit Floor

- Provide a pit floor at a minimum of 13 inches (14 inches with buffer springs) from the top of the finished floor to the highest point in the pit.
- If required, the pit shall have means to prevent the collection of ground water.
- If provided with fire service, a drain or sump pump shall be provided to remove 3,000 gallons of water per hour.
- Provide a pit floor capable of supporting the loads below:
  - The maximum vertical force imposed on each guide rail upon application of the safety is approximately 4,800 lbs. for a total floor impact of 9,600 lbs. This load is applied at the respective T-rail locations on the base plate.
  - The impact load imposed on each buffer or bumper assembly is approximately 3,300 lbs. for a total floor impact load of 6,600 lbs. This load is applied at the respective buffer or bumper floor plate locations.
  - The approximate overall static net vertical load from the elevator system is 3,760 lbs. This value includes the capacity, car, sling, ram, ram's header and fluid weights and is applied at the ram location on the base plate.

### Overhead

- Provide a minimum overhead of 8'8" (104 inches) for existing construction.
- Provide a minimum overhead of 11'0" (132 inches) for new construction.

**Please note that this guide is for planning purposes only, applies exclusively to national code and should not be used for construction.**

*Prior to construction, please contact your local Symmetry Elevating Solutions representative and request a job-specific set of elevator plans to ensure that you obtain the accurate dimensions and requirements for your project.*

*Your representative will also assist you to identify resources to ensure that your project plans will comply with the applicable state and local codes and the permitting authorities.*

# Hoistway

## Typical rail backing construction

Each backing member is constructed of (3) 2 x 12's and (2) 2 x 6's on each end, laminated using wood glue and #8 x 2 3/4" screws (minimum).

If the backer span exceeds 10 feet or if the backing construction and/or materials are not as specified, please consult a structural engineer.

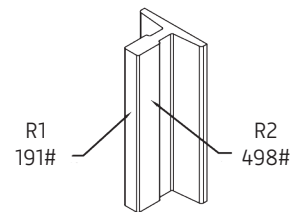
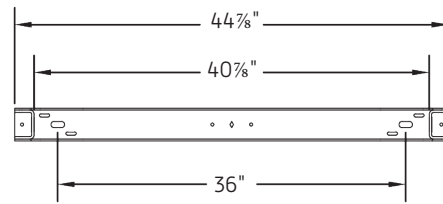
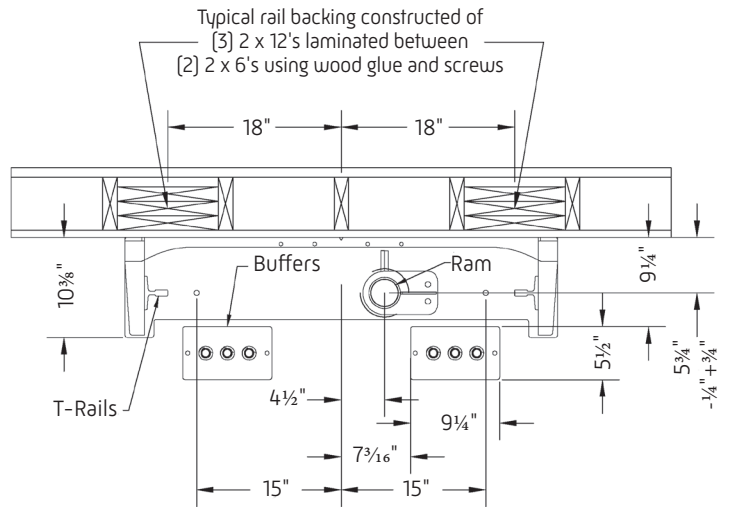
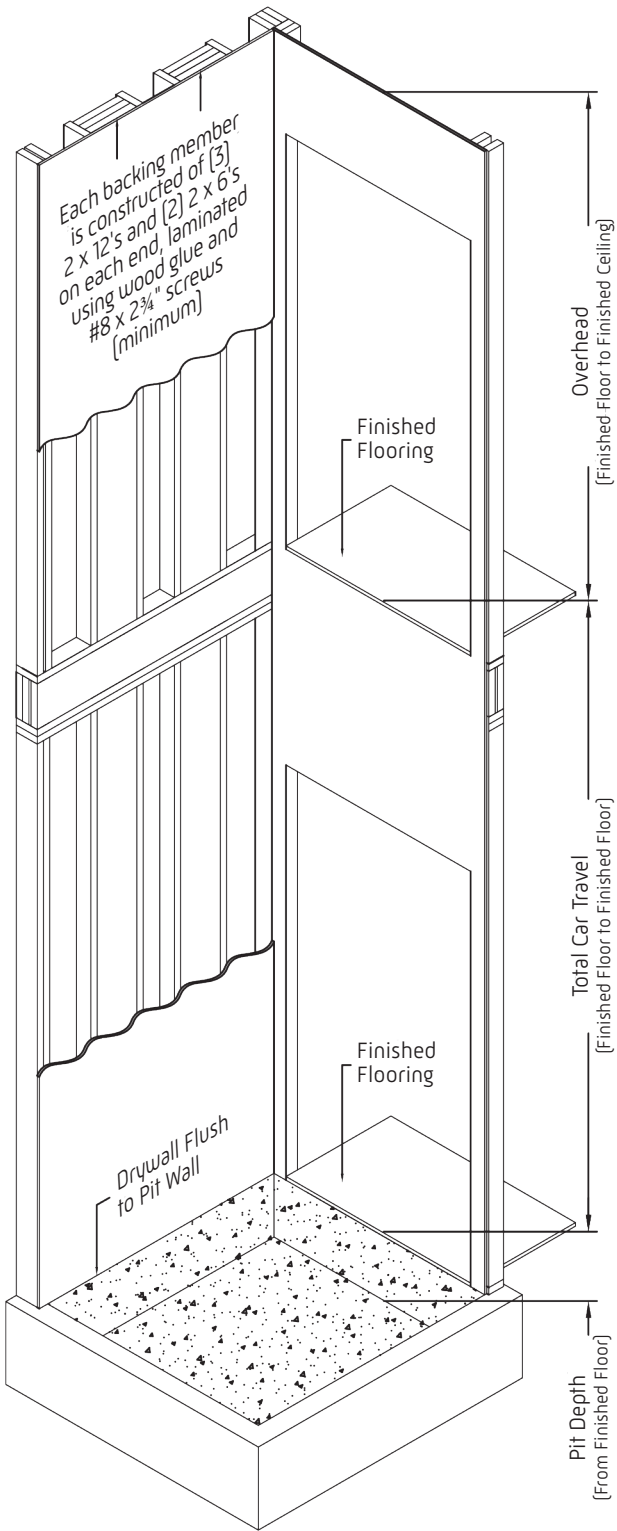

Static Rail Reaction  
(per rail)

# Configurations

## Single opening

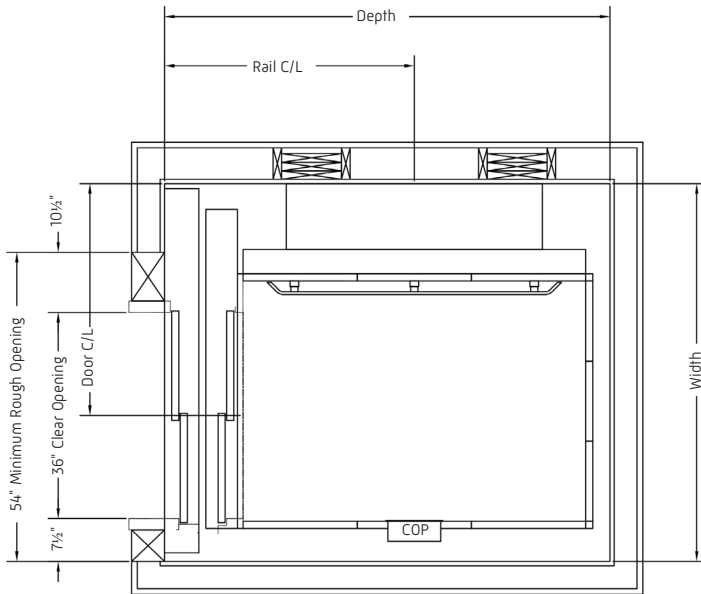

### Typical Single Opening

Rail Left, Right-Hand Door (shown)  
 Rail Right, Left-Hand Door (opposite)

Car Size	Width*	Depth	Rail C/L	Door C/L
42x54	66"	72"	40 $\frac{3}{4}$ "	40 $\frac{1}{2}$ "
42x60	66"	78"	43 $\frac{3}{4}$ "	40 $\frac{1}{2}$ "
48x54	68"	72"	40 $\frac{3}{4}$ "	42 $\frac{1}{2}$ "

\*Add 2 inches to width if a pit ladder is required

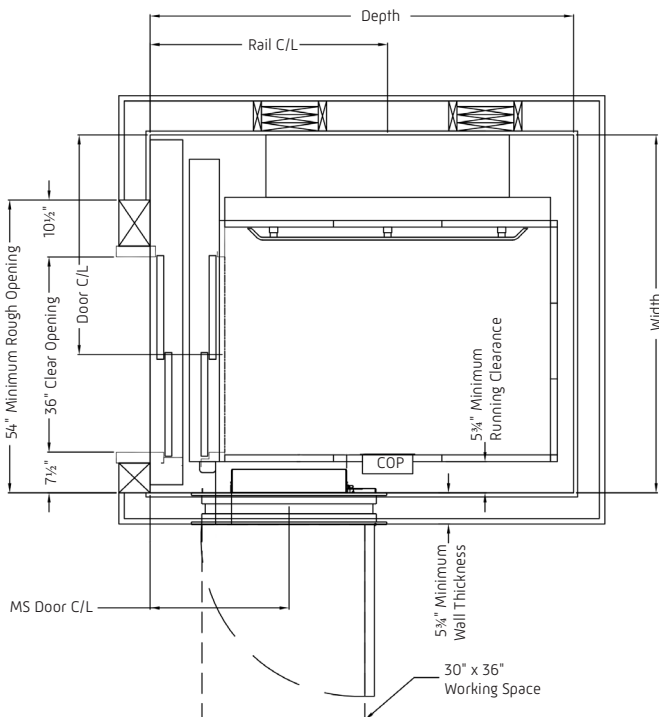

### Single Opening - MRL Option

Rail Left, Right-Hand Door (shown)  
 Rail Right, Left-Hand Door (opposite)

Car Size	Width*	Depth	Rail C/L	Door C/L	32" MS Door C/L	36" MS Door C/L
42x54	66"	72"	40 $\frac{3}{4}$ "	40 $\frac{1}{2}$ "	26 $\frac{1}{8}$ "	20 $\frac{7}{8}$ "
42x60	66"	78"	43 $\frac{3}{4}$ "	40 $\frac{1}{2}$ "	27 $\frac{5}{8}$ "	20 $\frac{7}{8}$ "
48x54	68"	72"	40 $\frac{3}{4}$ "	40 $\frac{1}{2}$ "	26 $\frac{1}{8}$ "	20 $\frac{7}{8}$ "

\*Add 2 inches to width if a pit ladder is required

\*\* Machine space must be opposite rail wall, but may be at any landing

\*\*\* If fusible disconnects are required in the machine space, minimum wall thickness is 8"

# Configurations

## Opposite opening

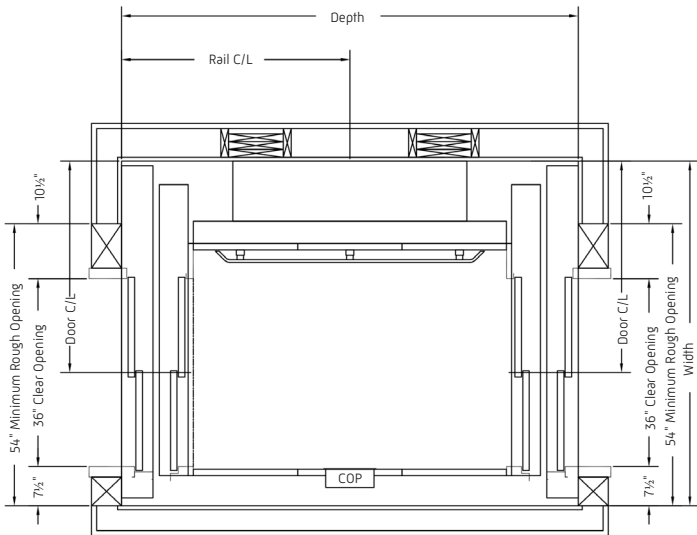

### Typical Opposite Opening

Rail Left, Right-Hand Door, Left-Hand Door  
 Rail Right, Left-Hand Door, Right-Hand Door

Car Size	Width*	Depth	Rail C/L	Door C/L
42x54	66"	81½"	40¾"	40½"
42x60	66"	87½"	43¾"	40½"
48x54	68"	81½"	40¾"	42½"

\*Add 2 inches to width if a pit ladder is required

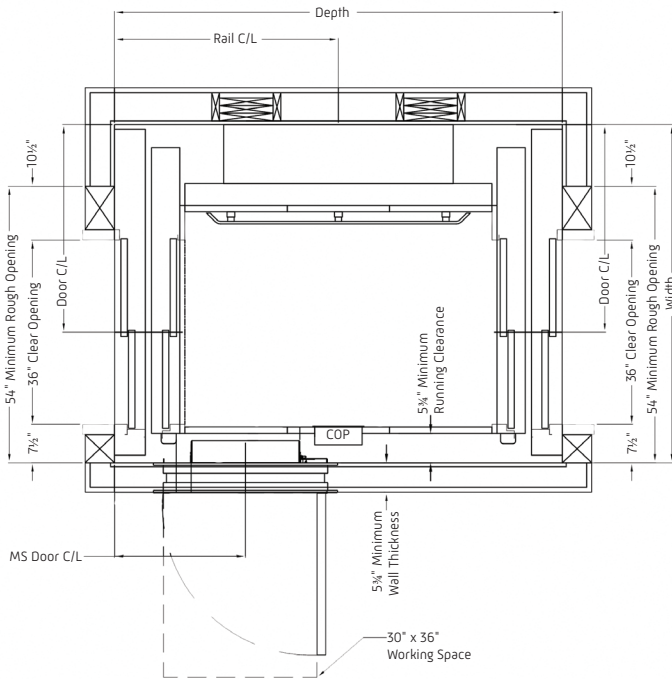

### Opposite Opening - MRL Option

Rail Left, Right-Hand Door, Left-Hand Door  
 Rail Right, Left-Hand Door, Right-Hand Door

Car Size	Width*	Depth	Rail C/L	Door C/L	32" MS Door C/L**	36" MS Door
42x54	66"	81½"	40¾"	40½"	26⅞"	20⅞"
42x60	66"	87½"	43¾"	40½"	27⅞"	20⅞"
48x54	68"	81½"	40¾"	42½"	26⅞"	20⅞"

\* Add 2 inches to width if a pit ladder is required

\*\* Machine space must be opposite rail wall, but may be at any landing

\*\*\* If fusible disconnects are required in the machine space, minimum wall thickness is 8"

# Configurations

## 90° Opening

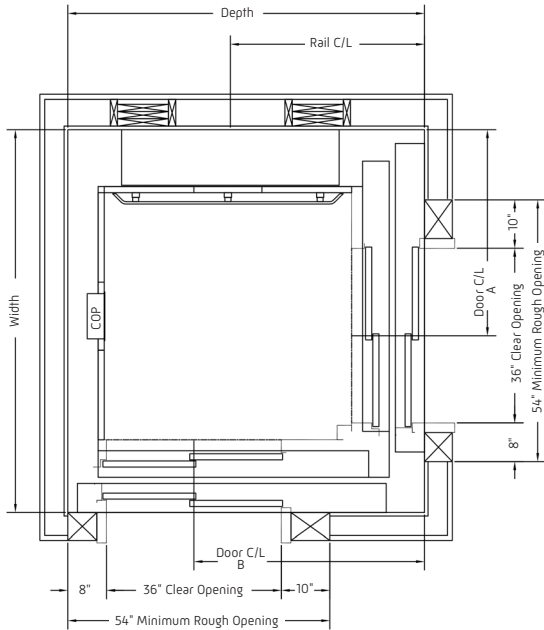

**Typical 90° Opening**  
 Rail Right, Left-Hand Doors (shown)  
 Rail Left, Right-Hand Doors (opposite)

Car Size	Width	Depth*	Rail C/L	Door C/L A	Door C/L B
51x51	79"	73½"	40"	36½"	47½"

\*Add 2 inches to depth if a pit ladder is required

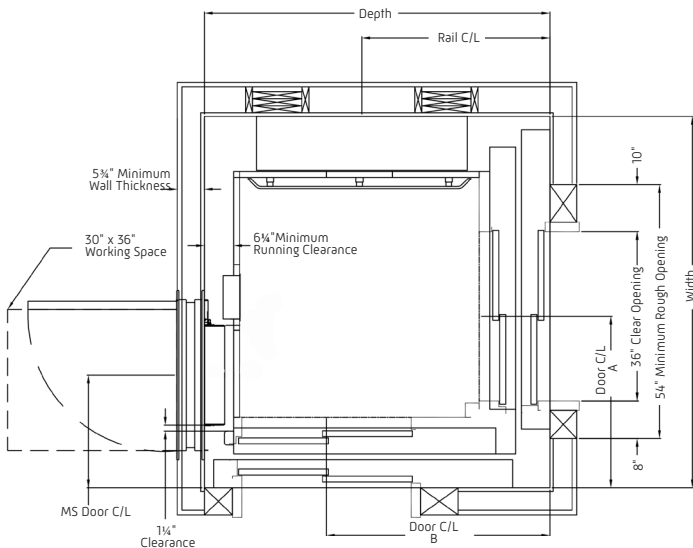

**90° Opening - MRL Option**  
 Rail Right, Left-Hand Doors (shown)  
 Rail Left, Right-Hand Doors (opposite)

Car Size	Width	Depth*	Rail C/L	Door C/L A	Door C/L B	32" MS Door C/L**	36" MS Door C/L**
51x51	79"	73½"	40"	36½"	47½"	26"	20⅞"

\* Add 2 inches to depth if a pit ladder is required

\*\* Machine space must be adjacent to rail wall in 90° applications, but may be at any landing

\*\*\* If fusible disconnects are required in the machine space, minimum wall thickness is 8"



PART OF CIBES LIFT GROUP



## AIA Continuing Education [symmetryelevator.com/aia](https://symmetryelevator.com/aia)

Symmetry offers courses to obtain continuing education credits. Each completed course is worth 1 (one) LU|HSW credit. Choose from a detailed review of residential elevators, vertical platform lifts (VPLs), limited use/limited application (LULA) elevators or vertical reciprocating conveyors (VRCs).

The courses also address: code application, specification, suitability of product type, the direct governance guidelines of ADA, ANSI and ASME, and site conditions required for a successful final installation.